



FPS220 series

Digital differential pressure sensor

Features

- Supply voltage:
 - 1.7 to 5.5V(V_{DD})
 - 1.2 to 5.5V(V_{DDIO})
- 20、70hPa、100kPa pressure range
- Standby current $<0.1\mu A$
- I²C and SPI interfaces
- Calibrated and temperature compensated

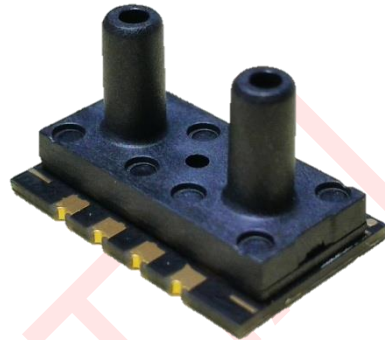

Application Examples

- Air flow measurement
- HVAC
- Industrial control
- Leak detection
- Air filter monitoring

Descriptions

The FPS220 is a new generation of high resolution digital barometer. The FPS220 is a digital pressure sensor which consists of a MEMS piezoresistive pressure sensor and a signal conditioning ASIC. The ASIC include a 24bits sigma-delta ADC, OTP memory for calibration data, and serial interface circuits. The FPS220 could provide both I²C and SPI interface to communicate with microcontroller.

Pressure calibrated and temperature compensated were key features of the FPS220. The data stored in OTP memory could be used to calibrate the FPS220. The calibration procedure should be implemented by a external microprocessor. The FPS220 is low power and supply voltage designed and suitable for portable devices or battery-supplied ones.

Ordering information

Part No.	Pressure type	Pressure range	Digital interface	Note
FPS220-D20HDT	Diff.	0~20 hPa	SPI / I ² C	0~0.29 PSI
FPS220-D70HDT	Diff.	0~70 hPa	SPI / I ² C	0~1 PSI
FPS220-D10KDT	Diff.	0~100 kPa	SPI / I ² C	0~14.5 PSI



Index of contents

1	Functional Block and Pin Descriptions.....	3
2	Electrical Characteristic	4
3	Absolute Maximum Conditions	5
4	Application Information.....	5
5	Control registers.....	6
6	SPI Interface.....	7
7	I ² C Interface	9
8	Package Information	11
8.1	Outline dimensions	11
8.2	Recommended footprint.....	12
9	Document history and modification.....	12

CONFIDENTIAL

1 Functional Block and Pin Descriptions

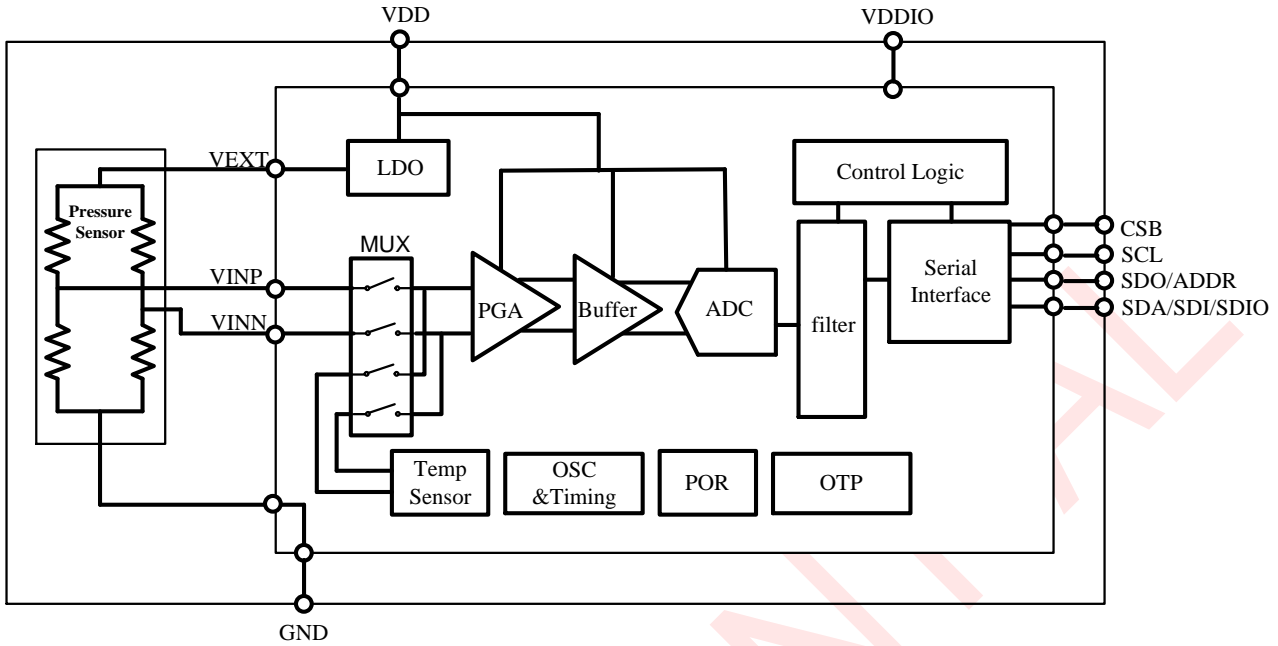
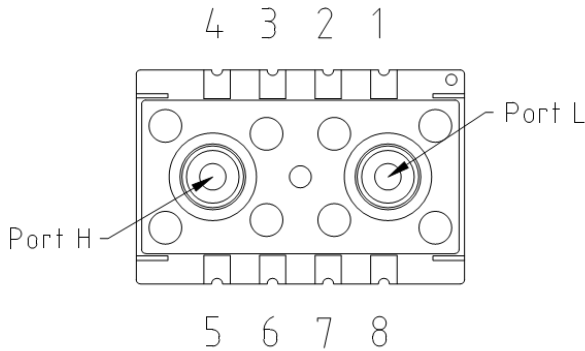

Fig. 1 Functional Block Diagram of FPS220



Pin No.	Pin Name	Description
1	N/C	Not connected
2	CSB	Chip Select
3	V _{DDIO}	Power supply for I/O circuits
4	V _{DD}	Power supply for core circuits
5	GND	Ground
6	SDO/ADDR	Serial data output in 4-wire SPI mode Address select in I ² C mode
7	SCL	Serial clock
8	SDA/SDI/SDIO	Serial data input/output in I ² C mode(SDA) Serial data input in 4-wire SPI mode(SDI) Serial data input/output in 3-wire SPI mode (SDIO)
Port H/L	Inlets for high/low pressure	Port H is for high pressure input and Port L for low one. Please make sure to keep that the pressure in port H is always higher than Port L.



2 Electrical Characteristic

Parameter	Symbol	Conditions	Min	Typ	Max	Units	Notes	
Pressure Range FPS220-D20HDT FPS220-D70HDT FPS220-D10KDT			0		20 70 100	hPa hPa kPa		
Operating Temperature Range			-40		125	°C		
Supply Voltage	V _{DD}		1.7	3.3	5.5	V		
	V _{DDIO}		1.2		5.5	V		
Supply Current	I _{DD}	1 conversion/sec.						
Pressure measurement								
Ultra low power				3.0	3.5			
Standard				4.7	6.4		μA	
High resolution				7.7	8.9			
Ultra high resolution		13.9	16.0					
Temperature measurement		1.9	2.2					
Peak Current During Conversion	I _{peak}							
Pressure measurement				1.51		mA		
Temperature measurement				0.95				
Standby Current	I _{sd}			<0.1		μA		
Conversion time								
Pressure measurement								
Ultra low power				2.2	2.5			
Standard				3.3	3.7	ms		
High resolution				5.4	6.0			
Ultra high resolution				9.8	10.7			
Temperature measurement				2.2	2.5			
Relative Pressure Accuracy		65~85°C 0~65°C -20~0°C -40~-20°C	-1	±0.5	1	%FS		
Absolute Pressure Accuracy		65~85°C 0~65°C -20~0°C -40~-20°C	-2 -1.5 -2.5 -3.5	±1 ±0.5 ±1.5 ±2	2 1.5 2.5 3.5	%FS		
Noise in pressure (20hPa)								
Ultra low power				0.096	0.283			
Standard				0.065	0.2	Pa	RMS noise	
High resolution				0.049	0.142			
Ultra high resolution				0.038	0.101			
Noise in pressure (70hPa)								
Ultra low power				0.664	2.92			
Standard				0.482	2.065	Pa	RMS noise	
High resolution				0.361	1.46			
Ultra high resolution				0.268	1.033			
Noise in pressure (100kPa)								
Ultra low power				3.109	4.663			
Standard				2.2	3.3	Pa	RMS noise	
High resolution				1.557	2.336			
Ultra high resolution				1.104	1.655			
Absolute temperature accuracy		@25°C 0~65°C	-1.5 -2	±0.5 ±1	1.5 2	°C		
Soldering drift		After solder reflow		TBD				
Long term stability		12 months		TBD				

1. All the data were measured with 3.3V supply voltage at a temperature of $25\pm 3^{\circ}\text{C}$, unless otherwise noted.
2. Relative pressure accuracy means the pressure output subtract zero offset.

3 Absolute Maximum Conditions

Parameter	Symbol	Conditions	Min	Typ	Max	Units	Notes
Supply Voltage	AVDD		-0.3		6.5	V	
	VDDIO		-0.3		6.5	V	
Analog pin voltage			-0.3		AVDD+0.3	V	
Digital output voltage			-0.3		VDDIO+0.3	V	
Storage Temperature Range			-40		125	$^{\circ}\text{C}$	
Maximum Overpressure							TBD
ESD Rating HBM				2		kV	

4 Application Information

Owing to state of the art, the FPS220 build a new standard of digital differential pressure sensor. A 24bits sigma-delta ADC and a MEMS pressure sensor are integrated in a FR5 substrate. Pressure calibrated and temperature compensated were key features of the FPS220. The FPS220 is low power and supply voltage designed and suitable for portable devices or battery-supplied ones.

The data stored in OTP memory could be used to calibrate the FPS220. The calibration procedure should be implemented by a external microprocessor. By I²C or SPI interface, you can get the calibration data stored in OTP and the raw data of pressure and temperature. In order to get the correct pressure and temperature reading, the calculating procedure must be implemented in a microprocessor.

Application Circuit example

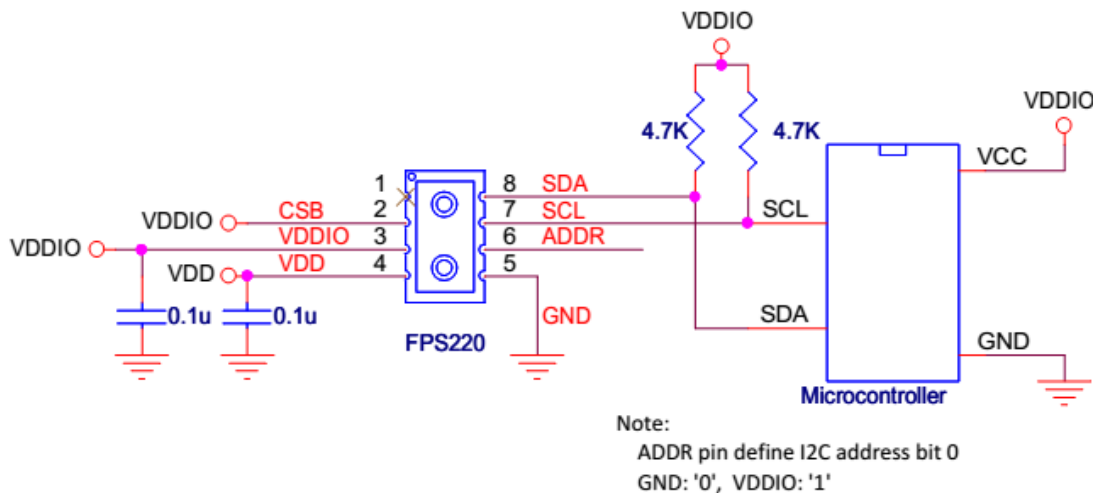

Figure. 4.1 Application circuit for I²C interface

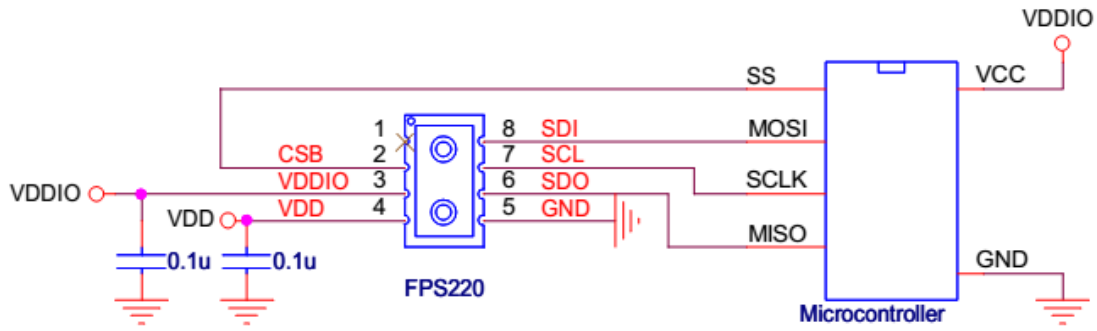

Figure 4.2 Application circuit for SPI interface

5 Control registers

Table 5.1 control registers

Addr	Description	R/W	Bit7	Bit6	Bit5	Bit4	Bit3	Bit2	Bit1	Bit0	Default
0xF8	DATA_LSB	R	Data out<7:0>								0x00
0xF7	DATA_CS	R	Data out<15:8>								0x00
0xF6	DATA_MSB	R	Data out<23:16>								0x00
0xF4	CONFIG_1	RW	OSR<1:0>		Measurement_control<5:0>					0x00	
0xF1	Cal_coeff	R	Calibration Registers								N/A
0xE0	Soft_reset	W	Softreset<7:0>								0x00
0xD0	Cal_coeff	R	Calibration Registers								N/A
0xBB-0xAA	Cal_coeff	R	Calibration Registers								N/A
0x6B	Part ID	R	PartID<7:0>								0x42
0x00	SPI_Ctrl	RW	SDO_active	LSB_fir st					LSB_fir st	SDO_active	0x00

Reg 0xF6–0xF8

Data_out: 24 bits ADC output data

Reg 0xF4

OSR<1:0>: 00:1024X, 01:2048X, 10:4096X, 11:8192X

Measurement_control<5:0>: 101110, indicate a temperature conversion. 110100, indicate a pressure conversion.

Reg 0xE0

Softreset : Write only register. If set to 0xB6, will perform a power on reset sequence. Auto returned to 0 after the soft reset completed.

Reg {0xF1, 0xD0, 0xBB:0xAA}



Calibration Registers : Total 20bytes calibration registers used for sensor calibration.

Reg 0x6B

PartID: 8 bits Part ID, the default value is 0x42.

Reg 0x00

SDO_active: 1: 4-wire SPI, 0: 3-wire SPI

LSB_first: 1: LSB first for SPI interface, 0: MSB first for SPI interface

Table 5.2 Summary of instructions

Instruction	Register address	Value
Pressure measurement, OSR1024	0xF4	0x34
Pressure measurement, OSR2048	0xF4	0x74
Pressure measurement, OSR4096	0xF4	0xB4
Pressure measurement, OSR8192	0xF4	0xF4
Temperature measurement	0xF4	0x2E
Softreset	0xE0	0xB6
3-wire SPI, MSB first	0x00	0x00
4-wire SPI, MSB first	0x00	0x81

6 SPI Interface

FPS220 provides both SPI and I²C interface for serial communication and ‘CSB’ pin is used to switch between these two protocols. Pulling ‘CSB’ pin low selects the SPI interface, leaving ‘CSB’ pin float or pulling it high selects the I²C interface. The SPI interface is compatible with SPI mode 0 (CPOL=0, CPHA=0).

Table 6.1 SPI interface specifications

Symbol	Parameter	Condition	Min	Max	Unit
f _{sclk}	Clock frequency	Max load on SDIO or SDO = 25pF		10	MHz
t _{sclk_l}	SCLK low pulse		20		ns
t _{sclk_h}	SCLK high pulse		20		ns
T _{sdi_setup}	SDI setup time		20		ns
T _{sdi_hold}	SDI hold time		20		ns
T _{sdo_od}	SDO/SDI output delay	Load = 25pF		30	ns
		Load = 250pF		40	ns
T _{csb_setup}	CSB setup time		20		ns
T _{csb_hold}	CSB hold time		40		ns

The figure below shows the definition of the SPI timing given in table 6.1

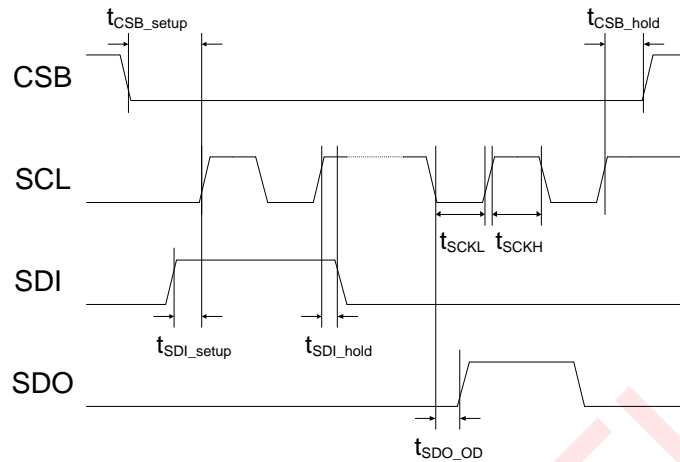

Figure 6.1 SPI timing diagram

The falling edge of CSB, in conjunction with the rising edge of SCLK, determines the start of framing. Once the beginning of the frame has been determined, timing is straightforward. The first phase of the transfer is the instruction phase, which consists of 16 bits followed by data that can be of variable lengths in multiples of 8 bits. If the device is configured with CSB tied low, framing begins with the first rising edge of SCLK.

The instruction phase is the first 16 bits transmitted. As shown in Figure 6.2, the instruction phase is divided into a number of bit fields.

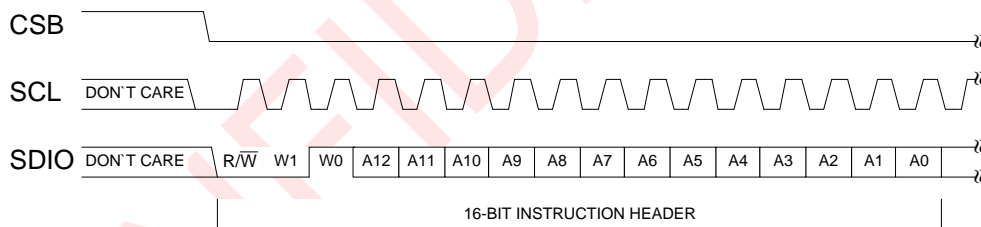

Figure 5.2 Instruction Phase Bit Field

The first bit in the stream is the read/write indicator bit (R/W). When this bit is high, a read is being requested, otherwise indicates it is a write operation.

W1 and W0 represent the number of data bytes to transfer for either read or write (Table 5.2). If the number of bytes to transfer is three or less (00, 01, or 10), CSB can stall high on byte boundaries. Stalling on a nonbyte boundary terminates the communications cycle. If these bits are 11, data can be transferred until CSB transitions high. CSB is not allowed to stall during the streaming process.

The remaining 13 bits represent the starting address of the data sent. If more than one word is being sent, sequential addressing is used, starting with the one specified, and it either increments (LSB first) or decrements (MSB first) based on the mode setting.

Table6.2. W1 and W0 settings

W1:W0	Action	CSB stalling
00	1 byte of data can be transferred.	Optional
01	2 bytes of data can be transferred.	Optional
10	3 bytes of data can be transferred.	Optional



11	4 or more bytes of data can be transferred. CSB must be held low for entire sequence; otherwise, the cycle is terminated.	No
----	---	----

Data follows the instruction phase. The amount of data sent is determined by the word length (Bit W0 and Bit W1). This can be one or more bytes of data. All data is composed of 8-bit words.

Data can be sent in either MSB-first mode or LSB-first mode (by setting ‘LSB_first’ bit). On power up, MSB-first mode is the default. This can be changed by programming the configuration register. In MSB-first mode, the serial exchange starts with the highest-order bit and ends with the LSB. In LSB-first mode, the order is reversed. (Figure 6.3)

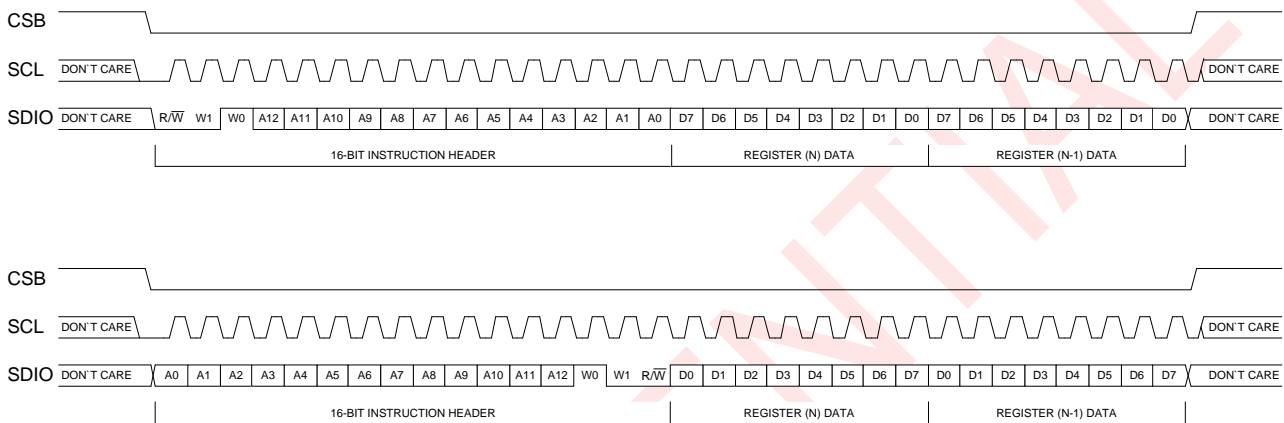

Figure5.3: MSB First and LSB First Instruction and Data Phases

Register bit ‘SDO_active’ is responsible for activating SDO on devices. If this bit is cleared, then SDO is inactive and read data is routed to the SDIO pin. If this bit is set, read data is placed on the SDO pin. The instruction and data phase is as shown in figure 6.4. The default for this bit is low, making SDO inactive.

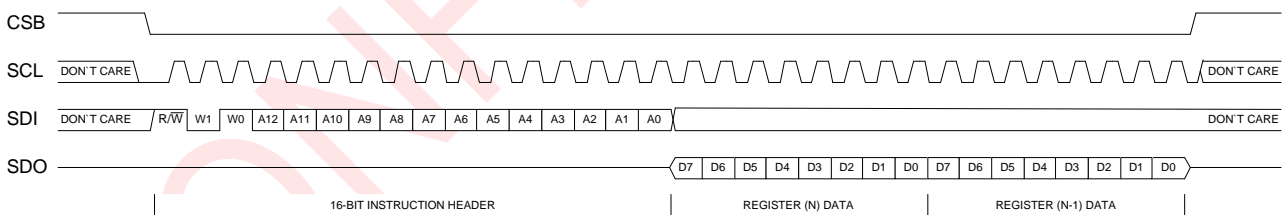

Figure 6.4 MSB First Instruction and Data Phases for 4-wires SPI Mode

7 I²C Interface

I²C bus uses SCL and SDA as signal lines. Both lines are connected to VDDIO externally via pull-up resistors so that they are pulled high when the bus is free. The I²C device address of FPS220 is shown below. The LSB bit of the 7bits device address is configured via SDO/ADDR pin. If the SDO/ADDR pin was left not connected or pulled high, the A1 bit is “1”. And the device address is “1101101”. For I²C bus application, ‘CSB’ pin have to be left float or pulled high.

Table 7.1 I²C Address.

A7	A6	A5	A4	A3	A2	A1	W/R
1	1	0	1	1	0	SDO/ADDR	0/1

Table 7.2 Electrical specification of the I²C interface pins

Symbol	Parameter	Condition	Min	Max	Unit
f_{scl}	Clock frequency			400	kHz
t_{LOW}	SCL low pulse		1.3		us
t_{HIGH}	SCL high pulse		0.6		us
t_{SUDAT}	SDA setup time		0.1		us
t_{HDDAT}	SDA hold time		0.0		us
t_{SUSTA}	Setup Time for a repeated start condition		0.6		us
t_{HDSTA}	Hold time for a start condition		0.6		us
t_{SUSTO}	Setup Time for a stop condition		0.6		us
t_{BUF}	Time before a new transmission can start		1.3		us

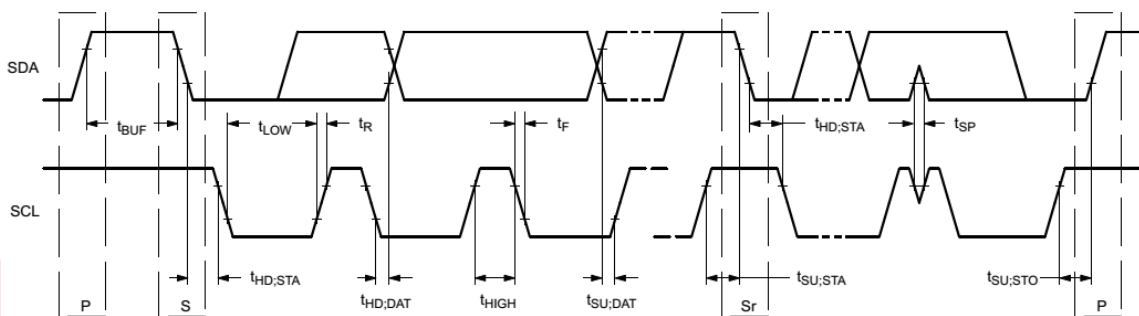

Figure 7.1 I²C Timing Diagram

The I²C interface protocol has special bus signal conditions. Start (S), stop (P) and binary data conditions are shown below. At start condition, SCL is high and SDA has a falling edge. Then the slave address is sent. After the 7 address bits, the direction control bit R/W selects the read or write operation. When a slave device recognizes that it is being addressed, it should acknowledge by pulling SDA low in the ninth SCL (ACK) cycle.

At stop condition, SCL is also high, but SDA has a rising edge. Data must be held stable at SDA when SCL is high. Data can change value at SDA only when SCL is low.

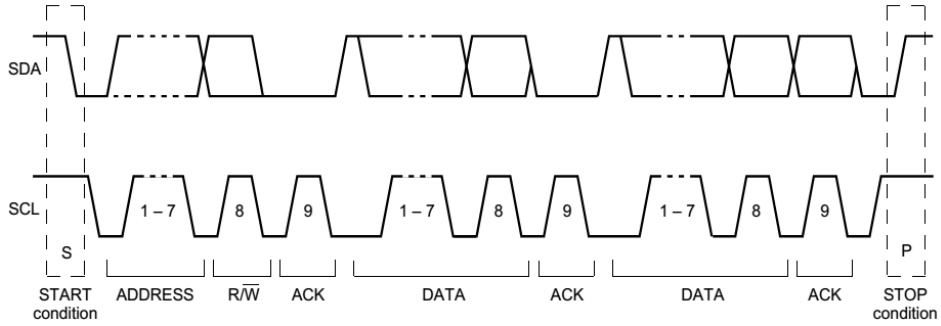
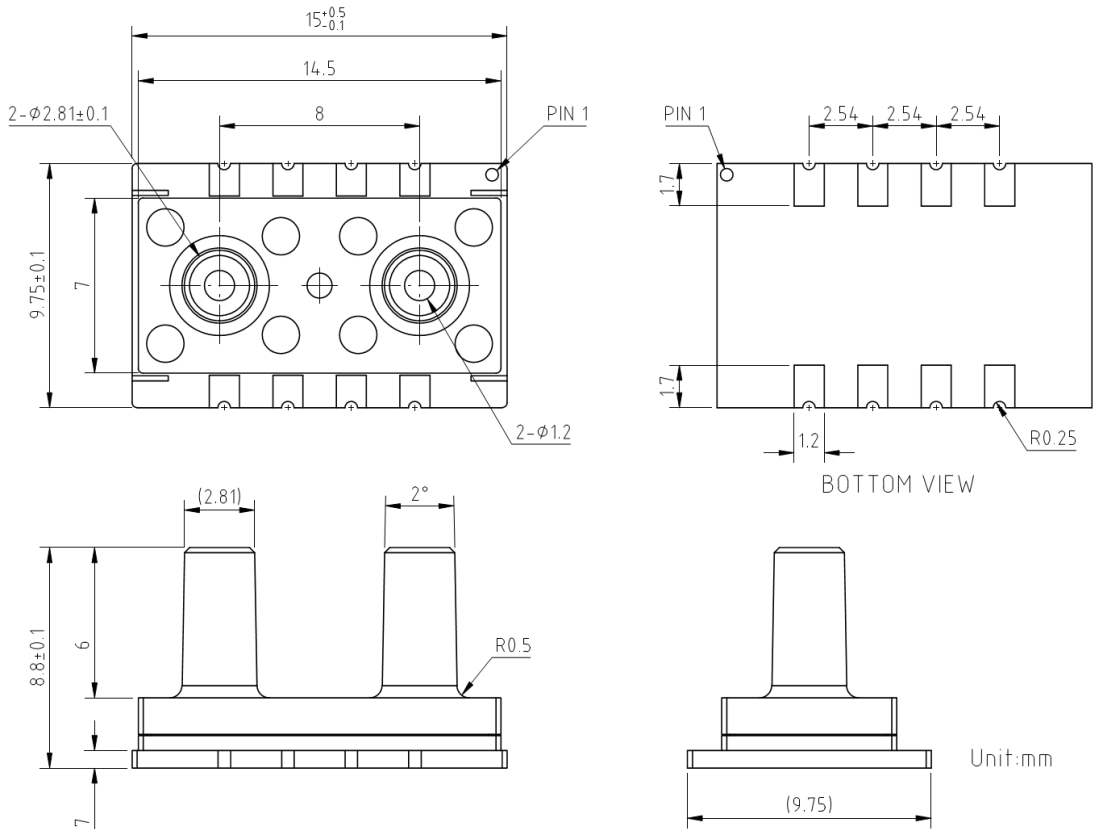

Figure 7.2 I²C Protocol

8 Package Information

8.1 Outline dimensions



8.2 Recommended footprint

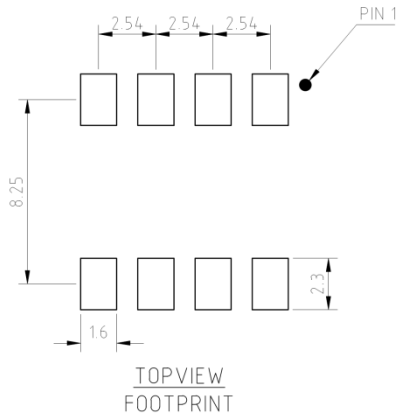

9 Document history and modification

Rev.	Description	Date
0.1	First edition (Preliminary)	2014/6/25
0.2	Added: Gage type part no., page 1 Modified: Ordering information, page 1 VDDIO 1.6 to 5.5V, page 1 Standby current <math><0.1\mu\text{A}</math>, page 1	2014/9/10
0.3	Modified: Product photo, page 1 Pin description, page 3 Description of Port H/L 8.1 Outline dimensions, page 11 8.2 Recommended footprint, page 11 Ordering information, page 1 0~10 hPa 0~20 hPa 0~10 kPa	2014/9/18
0.4	Modified: SPI waveform, Fig. 6.1, Fig. 6.2, Fig. 6.3, Fig. 6.4 Register table, description related to 0xF4, page 6 I ² C address “1101111”→”1101101”, page 9 FPS220-D01KDT pressure range, “0~10kPa”→”0~7kPa” Figure. 4.1 Application circuit for I ² C interface, page 5	2014/11/26
0.5	Modified: Function block diagram: Control Logics→Control Logic, page 3 Application circuit: Microcontrillor→Microcontroller, page 5 Reg0xF6-0xF8 → Reg 0xF6–0xF8, page 6 Reg 0xE0 RW→W, page 6 Rearrange register map, page 6	2015/1/15
0.6	Modified:	2015/10/2



	<p>1.8 to 5.5V(V_{DD})→ 1.7 to 5.5V(V_{DD}), page 1 1.6 to 5.5V(V_{DDIO})→ 1.2 to 5.5V(V_{DDIO}) , page 1</p> <p>Page 4:</p> <table border="1"> <thead> <tr> <th>Symbol^o</th> <th>Conditions^o</th> <th>Min^o</th> <th>Typ^o</th> <th>Max^o</th> <th>Units^o</th> </tr> </thead> <tbody> <tr> <td>°</td> <td>°</td> <td>300^o</td> <td>°</td> <td>1100^o</td> <td>hPa^o</td> </tr> <tr> <td>°</td> <td>°</td> <td>-40^o</td> <td>°</td> <td>85^o</td> <td>°C^o</td> </tr> <tr> <td>V_{DD}^o</td> <td>°</td> <td>1.7^o</td> <td>1.8^o</td> <td>5.5^o</td> <td>V^o</td> </tr> <tr> <td>V_{DDIO}^o</td> <td>°</td> <td>1.2^o</td> <td>°</td> <td>5.5^o</td> <td>V^o</td> </tr> </tbody> </table> <p>The values of conversion time in electrical characteristic table, page 4 2.2ms fastest conversion time, page 1 The photo of FPS220, page 1 The figure of pin definition, page 3 8.1 Outline dimensions, page 11 FR4→FR5, page 5</p>	Symbol ^o	Conditions ^o	Min ^o	Typ ^o	Max ^o	Units ^o	°	°	300 ^o	°	1100 ^o	hPa ^o	°	°	-40 ^o	°	85 ^o	°C ^o	V _{DD} ^o	°	1.7 ^o	1.8 ^o	5.5 ^o	V ^o	V _{DDIO} ^o	°	1.2 ^o	°	5.5 ^o	V ^o	
Symbol ^o	Conditions ^o	Min ^o	Typ ^o	Max ^o	Units ^o																											
°	°	300 ^o	°	1100 ^o	hPa ^o																											
°	°	-40 ^o	°	85 ^o	°C ^o																											
V _{DD} ^o	°	1.7 ^o	1.8 ^o	5.5 ^o	V ^o																											
V _{DDIO} ^o	°	1.2 ^o	°	5.5 ^o	V ^o																											
0.7	<p>Modified: 10、20、70hPa pressure range, page1 Part No.: FPS220-D70HDT, page1 Data of “Relative Pressure Accuracy”, page4 Data of “Absolute Pressure Accuracy”, page4 Data of “Noise in pressure”, page4</p>	2016/5/23																														
0.8	<p>Modified: 8.1 Outline dimensions, page 11</p>	2016/6/13																														
0.9	<p>Modified: Figure 4.1 and 4.2, page 5, 6</p>	2016/7/19																														
1.0	<p>Modified: Ordering information: FPS220-G10KDT→ FPS220-D10KDT</p>	2016/11/7																														
1.1	<p>Modified: Some errors were corrected.</p>	2017/3/13																														